

countR Scale – Data Sheet



- R420 ABS or R427 Stainless steel indicator.
- Built in AC power supply and line cord.
- Pre-configured for counting 250 products.
- Stainless steel frame pan and column.
- 5-point overload protection.
- Adjustable feet with levelling bubble.
- IP 65 Aluminium Load Cell.
- Printer and scanners optional.
- Ethernet and database functionality optional.

Rinstrum countR Scales feature our renowned rugged XG stainless steel base fitted with either a R420 or R427 indicator pre-configured for counting applications. countR bench scales are designed for years of easy operator use with an open frame making it easy to clean but also easy to find those dropped items under the pan. The top frame also has mounting points for a user supplied roller conveyor and the pan is robust enough to support ball transfer rollers. Fast response high accuracy loadcell and electronics to measure the smallest parts and pieces with accuracy.

A large multi-line backlight display can be tilted and rotated to the side as necessary, alpha numerical keypad to reduce user keyboard errors and even support for multi languages. The stainless column provides ergonomics plus it keeps the display away from falling parts or keyboard away from being covered by boxes or containers. countR can store up to 250 products with average piece weights being able to be viewed and updated, preset tare functionality, product count and weight totalising, custom printing with date and time and up to 6 user defined fields. 3 preconfigured setpoints available for checking over and under piece count or for use with a RYG light stack. As with all of our R420 and R427's there is the optional LUA databasing functionality, optional USB scanner input and ethernet network connectivity, datalogging to ensure accountability and additional I/O if necessary and to future proof your purchase.

Built to last

- Quality IP65 aluminium load cell.
- 300 x 300mm (12 in x 12 in) pan CR3030.
- 300 x 400mm (12 in x 16 in) pan CR3040.
- Maximum Capacity and readability.
 - AU/EU - CR3030 30kg x 0.001kg (66lbs x 0.002lbs)
 - US - CR3030 45kg x 0.001kg (100lbs x 0.002lbs)
 - US - CR3040 68kg x 0.002kg (150lbs x 0.005lbs)
- 304 stainless tubular steel frames.
- Overload protection stops.
- Replaceable Keypads.
- Overload recording increments every time the scale is overloaded.
- Future proof with LUA and USB and Ethernet options.
- 2 Year Warranty.

Easy maintenance & operation

- Clear open frame – Easy to keep clean and find parts under the pan.
- Sturdy pan construction – No warping.
- 2 Axis rotating head – For best operator viewing angle.
- Has ability to mount on roller conveyor or ball transfers.
- Language support for Spanish, French, German and Polish.



R420

- ABS housing
- AC/DC/Battery Power Options
- Operator friendly with multiline display and alpha numeric keypad
- Lua programmability option
- USB Host Port, Ethernet Port option



R427

- Stainless steel housing
- AC/DC/Battery Power Options
- Operator friendly with multiline display and alpha numeric keypad
- Lua programmability option
- USB Host Port, Ethernet Port option

Multi-Segment Display



Smart Weighing



A scale pre-configured for Counting with check weighing functionality.

countR scales are pre-configured for counting applications. The in-built check weighing function can be used to define two set points to indicate when the product count is reached to a certain value. Optional stack light can be connected to the scale easily for the indication of the check weighing.

...now that's smart weighing.

Specification Table

Product	CR3030-R42x		CR3040-R42x	
IP Rating Load Cell	IP65			
Pan Size	CR3030		CR3040	
	300x300mm (12in x 12in) pan		300x400mm (12in x 16in) pan	
Capacity	CR3030		CR3040	
AU/EU	30kg x 0.001kg (66lbs x 0.002lbs)		-	
US	45kg x 0.001kg (100lbs x 0.002lbs)		68kg x 0.002kg (150lbs x 0.005lbs)	
Materials				
Frame	304 Stainless Steel			
Pan	304 Stainless Steel			
Feet	304 Stainless Steel			
Load cell	Aluminium			
Indicator	R420	R427	R420	R427
Material	ABS	Stainless Steel	ABS	Stainless Steel
Keypad	23 Keys			
Display	LCD with 4 alpha-numeric displays and LED backlighting: Primary display: 6 x 28.4 mm high digits with units and annunciators 2nd display: 9 x 17.6 mm digits with units 3rd display: 8 x 6.1 mm digits 4th display: 4 x 7.6 mm digits			
Repeatability	+/- 1 division			
Linearity	+/- 1 division			
IP Rating Indicator	IP65	IP66	IP65	IP66
Serial	Serial 1A: RS-232 serial port for remote display, printer or serial barcode reader input. Serial 1B: RS-485 transmit only for remote display or network. Transmission rate: 2400, 4800, 9600 or 19200 baud			
Power Source				
AC	Internal AC power supply AU/US/EU line cord Input: 110/240VAC 50/60Hz Output: 12VDC 15VA			
Optional Battery	2.5AH NiMH rechargeable battery pack Charger Input: 110/240VAC 50/60Hz Output: 12VDC			
Firmware				
K402	250 Products, 6 user defined fields, custom printing, count resampling, average piece weight resampling, totalising, Pre-set Tare, Trade approved in weight mode, setpoints, Date & Time.			

Specifications are subject to variation for improvement, without notice.
 Illustrations are indications only and variation may be evident between products.

countR Scale Base Dimensions

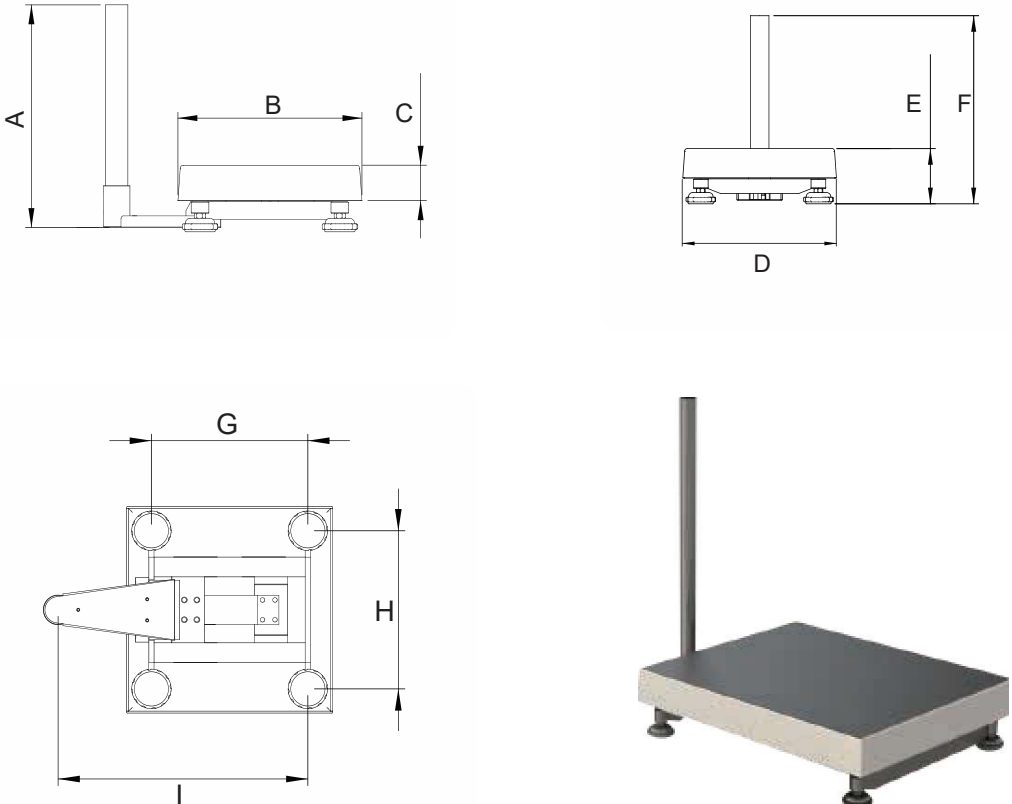
Scale Base Dimension				
				
Dimension	CR3030-R42x		CR3040-R42x	
	mm	in	mm	in
A	378	14.88	378	14.88
B	313	12.32	413	16.26
C	60	2.36	60	2.36
D	313	12.32	313	12.32
E	113	4.45	113	4.45
F	385	15.16	385	15.16
G	240	9.45	338	13.30
H	240	9.45	240	9.45
I	375	14.76	473	18.62

countR Scale Indicator Dimensions

