

SMART WEIGHING SOLUTIONS



**D841/ D850
Remote Displays
Installation Manual**

D800-600 Rev 2.0.1

Copyright

All Rights Reserved. No part of this document may be copied, reproduced, republished, uploaded, posted, transmitted, distributed, stored in or introduced into a retrieval system in any form, or by any means (electronic, mechanical, photocopying, recording or otherwise) whatsoever without prior written permission of Rinstrum Pty Ltd.

Disclaimer









Rinstrum Pty Ltd reserves the right to make changes to the products contained in this manual in order to improve design, performance or reliability. The information in this manual is believed to be accurate in all respects at the time of publication, but is subject to change without notice. Rinstrum Pty Ltd assumes no responsibility for any errors or omissions and disclaims responsibility for any consequences resulting from the use of the information provided herein.

Contents

1	Specifications	1
2	Installation	3
2.1	Introduction	3
2.2	Important	4
3	Power Connection	5
3.1	AC variant	5
3.2	DC variant	5
4	Communication Connections	6
4.1	Earthing Requirements for Cable Shields	6
4.2	Serial Connection	6
4.3	Ethernet (Optional)	8
5	Traffic Light Control (D841)	9
5.1	From Internal 5V DC Source (Serial communications connection variant only)	9
5.2	From an External DC Source (Serial and Ethernet communications variants)	9
6	Setup Command	10
6.1	Sending the Setup Command	11
7	Scrolling Messages (K802 firmware in D841 Only)	13
8	Mounting Options	14
8.1	Wall Mounting	14
8.2	Weather Hood (Optional)	14
8.3	Mounting Plate (Optional) (D841 only)	14
8.4	Dimensions	16
9	Error Messages	17
10	Appendix A : Supported Protocols	18

1. SPECIFICATIONS

Display	
Display	<p>D841 – Full LED Dot Matrix with up to seven (7) full alpha numeric characters with decimal point at 120 degrees viewing angle.</p> <ul style="list-style-type: none"> • Character size (H x W) – 100mmx60mm (4"x2.4") • 14 x 64 LED matrix at 14 x 8 LEDs per character • Status annunciators for Motion, Centre of Zero and Net • kg, lb, t, g, tn and oz units • 50mm (2") round RED and GREEN traffic lights <p>D850 – Full LED Dot Matrix with up to seven (7) full alpha numeric characters with decimal point at 120 degrees viewing angle.</p> <ul style="list-style-type: none"> • Character size (H x W) – 140mmx80mm (5.5"x3.2") • 14 x 64 LED matrix at 14 x 8 LEDs per character • Status annunciators for Motion, Centre of Zero and Net • kg, lb, t, g, tn and oz units
Performance	
Visibility	<p>D841 – Greater than 30m (100 feet) at 120 degrees viewing angle D850 – Greater than 70m (230 feet) at 120 degrees viewing angle</p>
Update Rate	Dependent on data update rate
Operating Environment	<p>Temperature: –20 to +60°C, -4 to 140°F case temperature Humidity:<90% RH non-condensing Storage: –20 to +60°C, -4 to 140°F ambient</p>
Digital	
Setup	Automatic detection with adjustment via a command string
Memory	Full non-volatile operation
Dimensions	
External Dimensions L x H x D	<p>D841 – 760mm x 150mm x 80mm (30" x 6" x 3.2") D850 – 799mm x 200mm x 80mm (31.5" x 8" x 3.2")</p>
Display Window L x H	<p>D841 – 515mmx115mm (20.3"x4.5") D850 – 644mmx135mm (25.4"x5.3")</p>
Weight	<p>D841 - 4.6 kg (10.2 lb) D850 - 6 kg (13.2 lb)</p>
Power	
AC Power	110-240VAC 50/60Hz 32W MAX
DC Power (option)	12-24 VDC (9-36VDC) 50 W MAX
Features	
Data Inputs	<p>RS-232 – two wire, receive only RS-485 – two wire, receive only Ethernet (Optional)</p>
Baud Rate	Auto detect Baud 2400 to 19200, Parity and Bit detection
Unit Addressing	Up to 100 addresses supported (00-99)

Display Timeout	5 seconds on data loss (default), adjustable												
Protocol Selection	Auto detection, Locking with configuration string												
Traffic lights	Controlled by digital inputs or byte in supported protocol. D841 - Dedicated Red and Green												
Weight Display	Six (6) digits plus decimal point and annunciators or seven (7) plus decimal point for text-based protocols. Weight readings, setup information and errors will be shown. The decimal point will be displayed between digits as two LEDs. The decimal point does not affect number of digits displayed.												
Units	Sticker to indicate the measurement units of the displayed reading or shown with annunciators if configured.												
Annunciators	<p>Where the annunciators are supported in the protocol, there are three annunciator conditions.</p> <p>Notes:</p> <ul style="list-style-type: none"> ○ Some protocols do not support all annunciators. ○ Symbols are displayed directly or indicated using labels. <table border="1" style="width: 100%; border-collapse: collapse;"> <thead> <tr> <th style="width: 20%;">Symbol</th> <th style="width: 20%;">Name</th> <th style="width: 60%;">Description</th> </tr> </thead> <tbody> <tr> <td style="text-align: center;"></td> <td style="text-align: center;">ZERO</td> <td>Indicated when the indicator is displaying Centre Of Zero.</td> </tr> <tr> <td style="text-align: center;"></td> <td style="text-align: center;">NET</td> <td>Indicated when the indicator shows NET weight.</td> </tr> <tr> <td style="text-align: center;"></td> <td style="text-align: center;">MOTION</td> <td>Indicated when the indicator reading is not stable.</td> </tr> </tbody> </table>	Symbol	Name	Description		ZERO	Indicated when the indicator is displaying Centre Of Zero.		NET	Indicated when the indicator shows NET weight.		MOTION	Indicated when the indicator reading is not stable.
Symbol	Name	Description											
	ZERO	Indicated when the indicator is displaying Centre Of Zero.											
	NET	Indicated when the indicator shows NET weight.											
	MOTION	Indicated when the indicator reading is not stable.											
Brightness Control	Adjustable 10 steps and Auto Detect. Full Brightness Default												
Scrolling Messages	Available in D841 only using K802 Factory fit Firmware, up to 150 characters at slow/medium/fast rate												
Approvals	FCC, CE, C-tick												
NTEP Multi Zero support	Multi zero support only applies to supported indicators and protocols. If the division size is 1x or higher, when the weight display returns to Zero, the D841/D850 will also display the trailing zero. Example: With the count set to 20, an indicator displays 00 at zero load. The D841/D850 will also show 00 at zero as there is no leading zero blanking. NTEP is the National Type Evaluation Program in the US.												
Optional Accessories													
	D841 only – D84x Weather Hood (DA002)												
	D841 only – Pole mounting plate (RAM and VESA mounting compatible) (DA003)												

2. INSTALLATION

2.1 Introduction

The D841 and D850 are super bright LED displays that feature full alpha numeric characters. These displays are capable of interpreting and displaying formatted weight transmissions from digital weight indicators. Additionally, they can be used to display text.

These remote displays are capable of displaying up to 7 alpha numeric digits on an LED matrix. Motion and Net annunciators are graphically shown on the display with the Centre of Zero shown as a pointer to a label. Weighing units kg, lb, g, t, tn and oz can also be graphically displayed. The complete annunciator section can also be left- or right-hand justified of the weight string.

The serial interface supports RS-232 and RS-485 as standard with an Ethernet option also available. Facilities for automatic selection of data source and baud rate are also standard. The remote displays are individually addressable which allows a single device to send targeted information to multiple displays.

These units are suitable to use in external applications and are designed to an IP65 rating. An optional weather hood is available to minimise effects of direct sunlight. The unit can be mounted on a flat surface with standard brackets or fixed to a pole using the optional mounting plate. The mounting plate also supports RAM and VESA mounting brackets.



Figure 1: D841 remote display

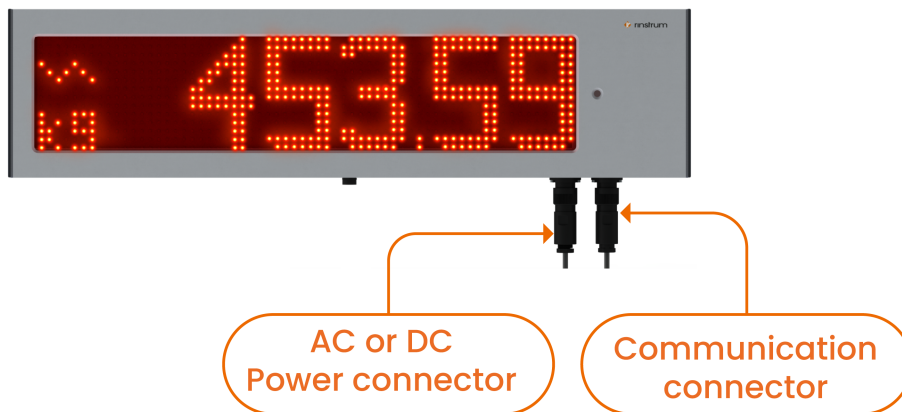

Figure 2: D850 remote display

2.2 Important

The D841 and D850 remote display units contain precision electronics and must not be subjected to shock, excessive vibration, or extremes of temperature, either before or after installation.

The serial and power inputs of the displays are protected against electrical interference; however excessive levels of electro-magnetic interference may affect the operation of the instrument. The remote display units should be installed away from any sources of electrical noise and the power and data cables should run separately from other sources of electrical interference.

The housing is rated to IP65 with a breather valve located on the underside of the extrusion to prevent condensation build up. This area should not be subject to high pressure water or other fluids else internal damage may occur.

There are no user serviceable parts inside. Warranty will be void if the housing is opened or either of the seals are broken. All connections are made at the external sockets located on the bottom, right hand side. Ensure power cable is not connected to a live source before terminating the power connector. Make sure the environment is dry when terminating to prevent moisture ingress into sealed connectors.



Disconnect power
before opening cable
connector

3. POWER CONNECTION

The D841 and D850 remote displays are available with two different power input variants, AC and DC.

Note: The power connection should be performed in accordance with local regulations.

3.1 AC variant

Use an AC power source of 110-240VAC. The Protective Earth pin 4 **MUST** be connected to AC mains earth for both safety and EMC regulation compliance.

AC Power Connection

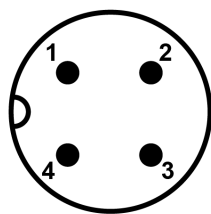

1. Active
2. Neutral
3. N/C
4. Protective Earth

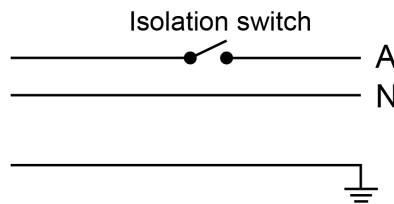

Use a power cable of min 0.75mm² (AWG 20) to max 2.5mm² (AWG 14)

Figure 3: AC power supply socket connection

3.2 DC variant

Use a DC power source of nominal 24VDC (9- 36VDC) only. The Earth pin 4 **MUST** be connected for both safety and EMC regulation compliance.

Note: DC power is not suitable for long cable runs. Be sure to allow for voltage drop in the power cable. Failure to do so may result in the display not operating and/or the power supply to be damaged.

DC Power Connection

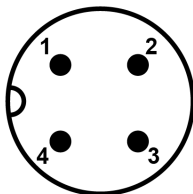

1. N/C
2. 0 VDC
3. 12-24 VDC
4. Earth

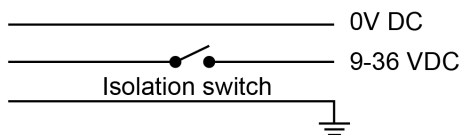

Use a power cable of 0.75mm² (AWG 20)

Figure 4: DC power supply socket connection

4. COMMUNICATION CONNECTIONS

The D841 and D850 remote displays are available with two different communication connection types, RS232/RS485 serial and Ethernet.

On power up, the display will attempt to automatically detect one of the communication protocols described in Appendix A⁽¹⁸⁾. Refer section Setup Command⁽¹⁰⁾ before connecting an indicator or PC with desired protocol.

4.1 Earthing Requirements for Cable Shields

Cable shields should ideally be connected to earth at one end for each of the communications options below. As there is no provision for the shield connection at the communications connection end of the display, it is recommended the shield be terminated at the indicator (source) end.

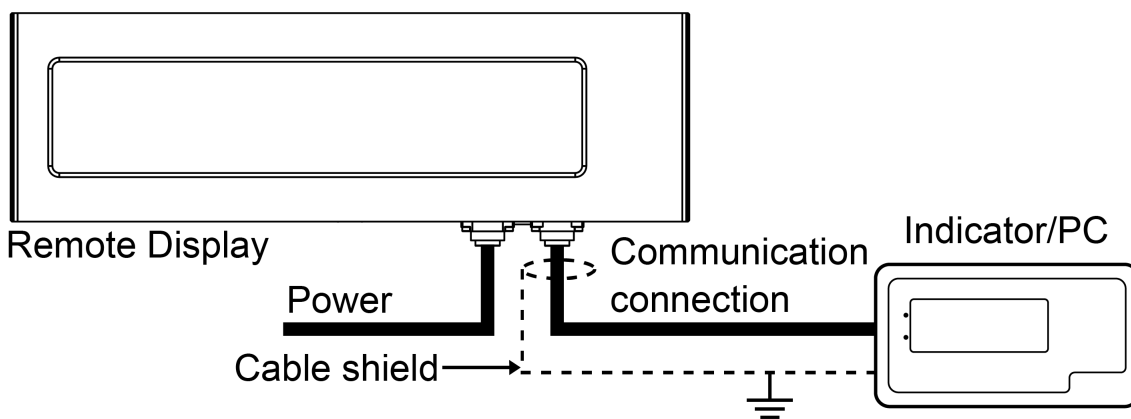

Figure 5: Shield Earthing

4.2 Serial Connection

The serial connection is used to transmit data to the remote display.

A shielded data cable should be used to prevent electrical noise interfering with the operation of the unit.

Communications Connection (Serial)

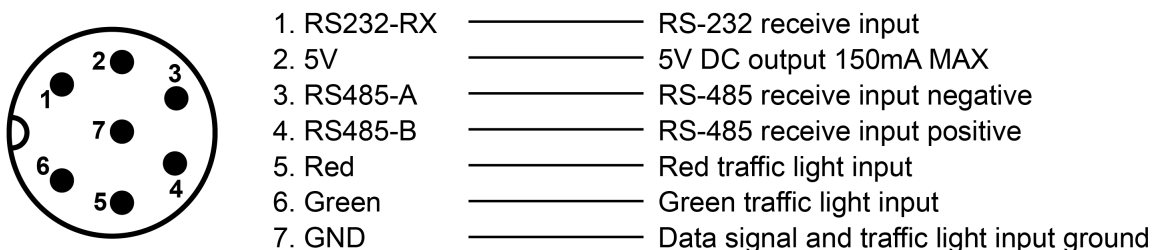

Figure 6: Serial socket connections

Notes:

- Pin 2 provides a 5V DC supply at a maximum current draw of 150mA. This supply can be used by clean contacts on relays or switches to operate the traffic lights.

- GND pin (7) is serial/digital input ground, NOT shield or power ground.

4.2.1 Baud Rate and Parity

Baud Rate, Parity and Data Bits are automatically detected. The baud rate can be 2400, 4800, 9600 or 19200. Parity and Data Bits supported are as follows:

Parity	Data bits	Examples	Description
(N)one	8	N81, N82	No parity, 8 data bits, 1 or 2 stop bits
(E)ven	7	E71, E72	Even parity, 7 data bits, 1 or 2 stop bits
(O)dd	7	O71, O72	Odd parity, 7 data bits, 1 or 2 stop bits
(M)ark	7	M71, M72	Mark parity, 7 data bits, 1 or 2 stop bits
(S)pace	7	S71, S72	Space parity, 7 data bits, 1 or 2 stop bits

4.2.2 RS-232 Receive Only

RS232 is not recommended for long cable runs or electrically noisy environments.

Communications Connection (Serial)

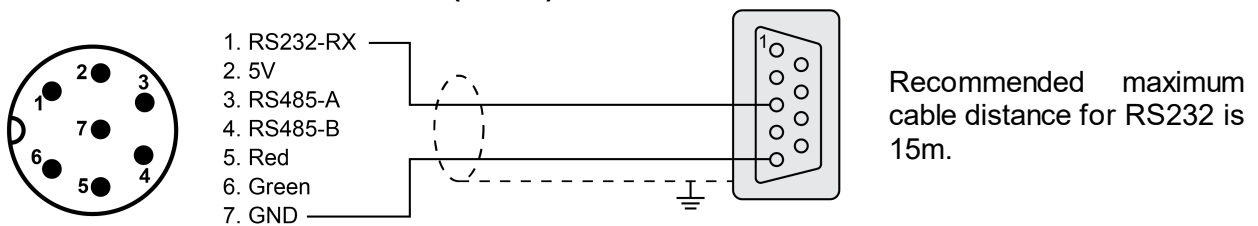

Figure 7: RS232 Socket connection

4.2.3 RS-485 Receive Only

RS485 is the preferred serial connection for long cable runs. Multi-dropping is supported. A 120Ω resistor is provided for termination.

Communications Connection (Serial)

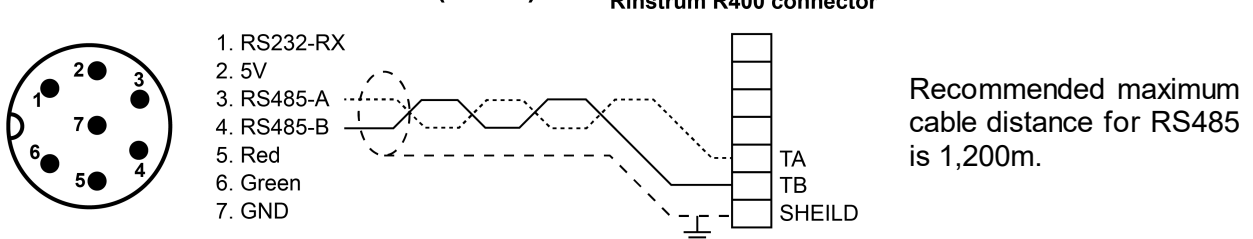

Figure 8: RS485 Socket connection

4.3 Ethernet (Optional)

Confirm the display has the Ethernet option fitted by taking note of the connection label located on the underside near the data input socket. The optional Ethernet connection has DHCP enabled by default. Confirm the site requirements for IP addressing with site IT personnel before configuring the display. Site Networking Security conflicts will cause set-up and operation issues.

If installing the display on an industrial network without a DHCP server, it is recommended you configure and test the display prior to installing on site and connecting to the industrial network.

4.3.1 Configure IP Address

You will require the Lantronix Device Installer to setup and configure the Ethernet option. You can download the Lantronix device installer from here: https://www.rinstrum.com/wp-content/uploads/Lantronix_DeviceInstaller_setup.zip

Install it onto your PC; connect your PC and the Remote to the same network. Do a broadcast search using the Lantronix Device Installer to find the display on the network. Use the MAC address located on the serial number label of the display.

Select the correct device and click "Assign IP". Enter in a valid IP address within the allowable range of the network and select "Assign". New IP address will be assigned to the device. When complete the device will be shown on table with new IP address and status "Online". For further information use the Help within the software.

Data to be displayed is sent as Serial over Ethernet, so any supported protocols can be used for the data format.

Note: The display listens on port 10001. Use this port with the assigned IP to connect to the display.

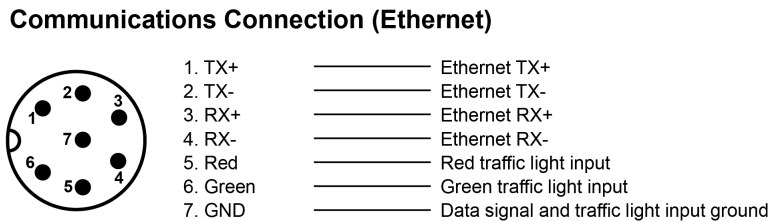

Figure 9: Ethernet socket connections

5. TRAFFIC LIGHT CONTROL (D841)

The traffic lights can be controlled by a control character in the supported protocols (refer Appendix A for supported protocols) or by digital inputs available on the communication connection socket. If the traffic light is set by serial communication, the digital input control of the traffic lights will be ignored until the power is cycled.

Note: D850 does not have dedicated traffic lights but will display "STOP" for Red, "GO" for Green and "-----" for both Red and Green inputs.

5.1 From Internal 5V DC Source (Serial communications connection variant only)

For remote operation of the traffic lights it is recommend using a twisted pair multi core cable with one pair for the data and another two pairs for the traffic light control to minimise interference. The switch contact will short the 5V on pin 2 to either pin 5 for RED and/or pin 6 for GREEN as per the diagram below.

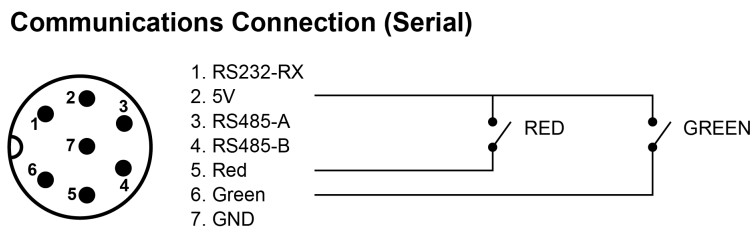

Figure 10: Driving traffic lights from internal 5VDC source

5.2 From an External DC Source (Serial and Ethernet communications variants)

To control the traffic lights from a remote DC power supply the following connections are required. It is recommend using a twisted pair multi core cable with one pair for the data and another two pairs for the traffic light control to minimise interference. The DC power supply 0VDC needs to be connected to pin 7 GND on the communications connector. The 5-24VDC supply is then run through the switching control device before been connected to pins 5 for RED and/or 6 for GREEN as per the diagram below.

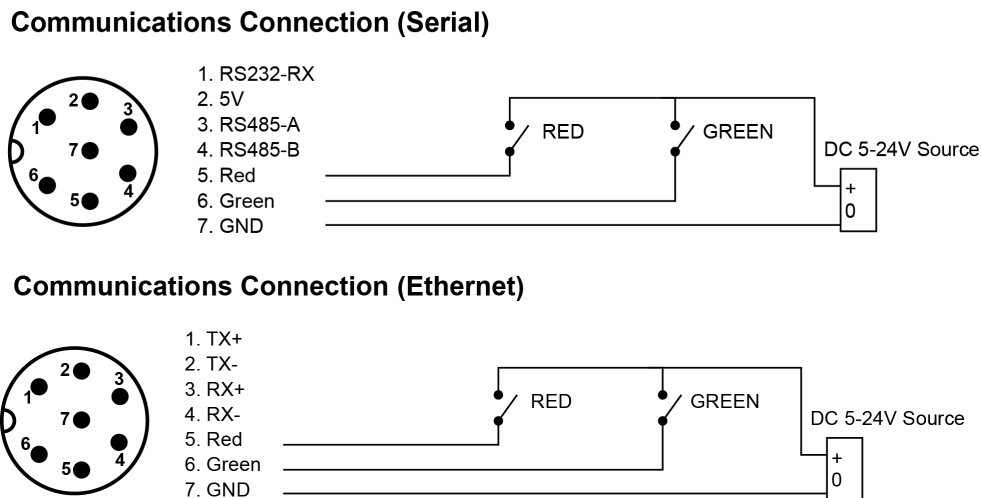

Figure 11: Driving traffic lights from external DC source

6. SETUP COMMAND

The display will auto-detect the Baud, Parity Bits on start-up when the string is being streamed to it. The Protocol can be left as auto detect which will require the remote to buffer 50 chars of data before selecting correct protocol match, this ok for device which stream the data out at a set rate. For system like PC software that only send a single string with new data when required the Auto Protocol detect may not display all messages sent. To overcome this, you can lock the protocol using the configuration string which will force the unit not to search on start-up but display first message received. The display will try and display all data received when in a locked state even if the protocol does not match. Check the start-up sequence if the remote is locked to the correct protocol (PR. 00 is auto). There is a list of settings that are configurable if the default values are not suitable. The reset string will default the unit and must be used prior to making changes. These settings can be altered with a setup command string which is required to be streamed to the display instead of the source device protocol prior to installation.

Reset String:

Character Number	0	1
Description	BEL	SOH

Function	Description
BEL	0x07 = Control Character BEL
SOH	0x01 = Control Character SOH - Start of Header

Configuration String:

Character Number	0	1	2	3	4	5	6	7	8	9	10
Description	STX	Annunciator position	Address Hi	Address Lo	Time Out Hi	Time Out Lo	Brightness	Save Settings	Protocol Hi	Protocol Lo	SPC
Character Number	11	12	13	14	15	16	17	18	19	20	
Description	SPC	SPC	SPC	SPC	SPC	SPC	SPC	SPC	SPC	ETX	

Function	Description
STX	0x02 = Start of Transmission

Annunciator position	0x30 - Left hand annunciators 0x31 - Right hand annunciators 0x32 - Left hand with units 0x33 - Right hand with units	Default: 0x30 *K801 only*
Address Hi	MSB of the address value 0 to 9 (0x30 to 0x39)	Default: 0x30
Address Lo	LSB of the address value 0 to 9 (0x30 to 0x39)	Default: 0x31
Time Out Hi	MSB of the Time out value, in seconds 0 to 9 (0x30 to 0x39)	Default: 0x30
Time Out Lo	LSB of the Time out value, in seconds 0 to 9 (0x30 to 0x39)	Default: 0x35
Brightness	Brightness value 0x30 = MAX to 0x39 = MIN 0x3A = Auto Detect	Default: 0x30
Save	0x56 = Save modified settings	
Protocol Hi	MSB of the Protocol value 0 to 9 (0x30 to 0x39)	Default: 0x30
Protocol Lo	LSB of the Protocol value 0 to 9 (0x30 to 0x39)	Default: 0x30
SPC	0x20 = Space	
ETX	0x03 = End of Transmission	

6.1 Sending the Setup Command

6.1.1 Rinstrum Remote Display Configurator

Use the Rinstrum D800 Remote Display Configurator software to configure the remotes. The software Versions 1.01 and higher are applicable to the string structure described here. The settable options are laid out in check boxes or drop-down menus with simple instructions shown.

6.1.2 Alternative Methods

The Configuration String can be streamed from a PC running terminal software such as "RealTerm", Android App "Slick USB" or similar. Alternatively, you can use the custom string format in the Rinstrum R400 series indicators to send the string (this method cannot currently be used for displays with Ethernet option).

Process:

- Remove power from the remote.
- Connect a suitable serial cable from the input of the display to your PC, tablet or R400 indicator and apply power. (For displays with Ethernet option, follow the instructions in the installation manual on how to install and configure this option)

- If the remote has not received and displayed a valid protocol prior to being reset from custom settings, then you will have send a supported protocol first to acknowledge the previous changes.
- Send the Reset String via the software or R400 indicator until.
- Display will show –OK— then reinitialize at default settings (Note: if the unit is already at default settings then the –OK— message will not be shown)
- Determine what settings need to be changed as based on the Configuration String. Set the suitable options in the software or create a custom string in the connected R400 Series indicator.
- Send the Configuration String out to the display until Proto 40 then –OK— is shown, (at least 6 times at 1 sec intervals best).
- The remote will now reinitialize with the new settings as shown in the start-up sequence.
- Disconnect power to the remote.
- If required disconnect the setup cable and reconnect the primary system device.
- Apply power to remote.
- Unit is ready for operation with the new configuration settings.

Examples: using RealTerm

- To change the Unit Address from the default value 01 to 35:

```
\0x02\0x30\0x33\0x35\0x30\0x35\0x30\0x56\0x30\0x30\0x20\0x20\0x20\0x20\0x20\0x20\0x20\0x20\0x20\0x20\0x20\0x20\0x03
```

- To change the Time-Out value to 0 seconds (thus disabling):

```
\0x02\0x30\0x30\0x31\0x30\0x30\0x30\0x56\0x30\0x30\0x20\0x20\0x20\0x20\0x20\0x20\0x20\0x20\0x20\0x20\0x20\0x20\0x03
```

- To Lock on Protocol 4 only:

```
\0x02\0x30\0x30\0x31\0x30\0x35\0x30\0x56\0x30\0x34\0x20\0x20\0x20\0x20\0x20\0x20\0x20\0x20\0x20\0x20\0x20\0x03
```

7. SCROLLING MESSAGES (K802 FIRMWARE IN D841 ONLY)

Scrolling messages are supported in the D841 using K802 firmware. The serial data string must be set to 9600 Baud Rate, No Parity, 8 Data Bits and 1 Stop Bit (9600 N81) and be framed with <SOH> and <ETX>. See Protocol 41 in the Protocol Manual for more information.

8. MOUNTING OPTIONS

Two stainless steel mounting brackets are used to mount the unit on a flat surface. These brackets are bolted to rear of the housing using the shake-proof nuts provided. The outer mounting holes are 8mm in diameter.

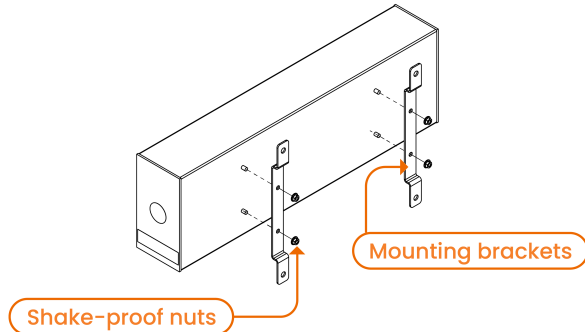

Figure 12: Mounting brackets

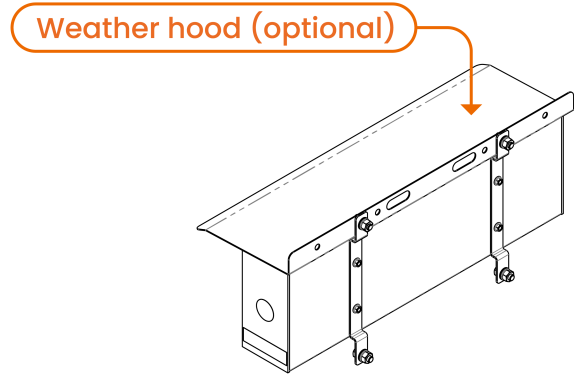

Figure 13: Optional weather hood

8.1 Wall Mounting

For wall mounting it is recommended that:

- 6mm or 1/4" bolts and washers be used as a minimum.
- Both Brackets are to be used with mounting hole centres at 250mm (9.8") wide and 200mm (7.9") high. Fit top bolts first to support display.

8.2 Weather Hood (Optional)

The optional weather hoods can be used to minimise effects of direct sunlight. The Weather Hood mounting holes line up with the wall mounting holes on the brackets for easy fitment.

Note: It is recommended when fitting the optional weather hood the two bottom bolts are loosely installed first to support the remote then the top two to aid in installation.

8.3 Mounting Plate (Optional) (D841 only)

The optional mounting plate for the D841 supports VESA, RAM and pole mounting.

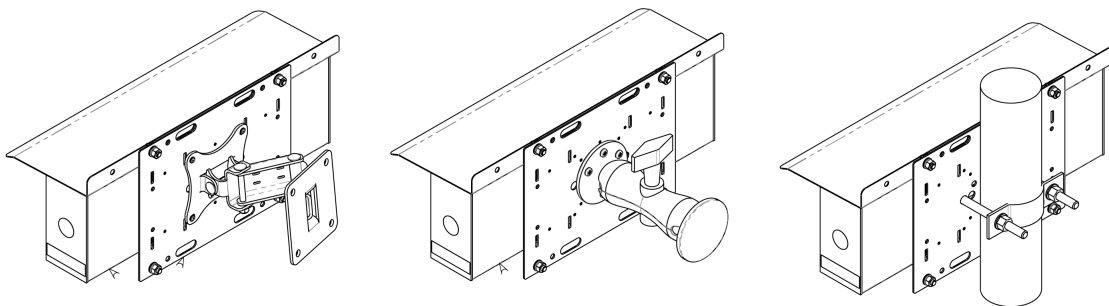

Figure 14: VESA, RAM and Pole mounting examples

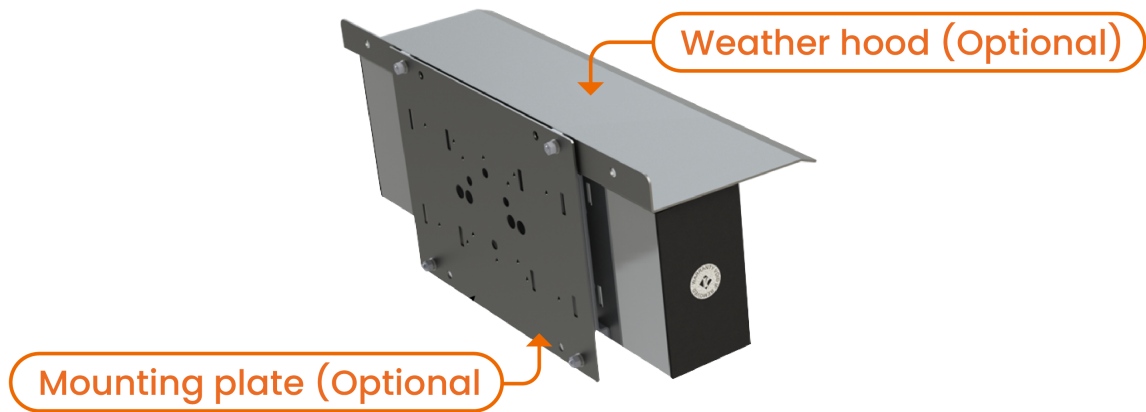
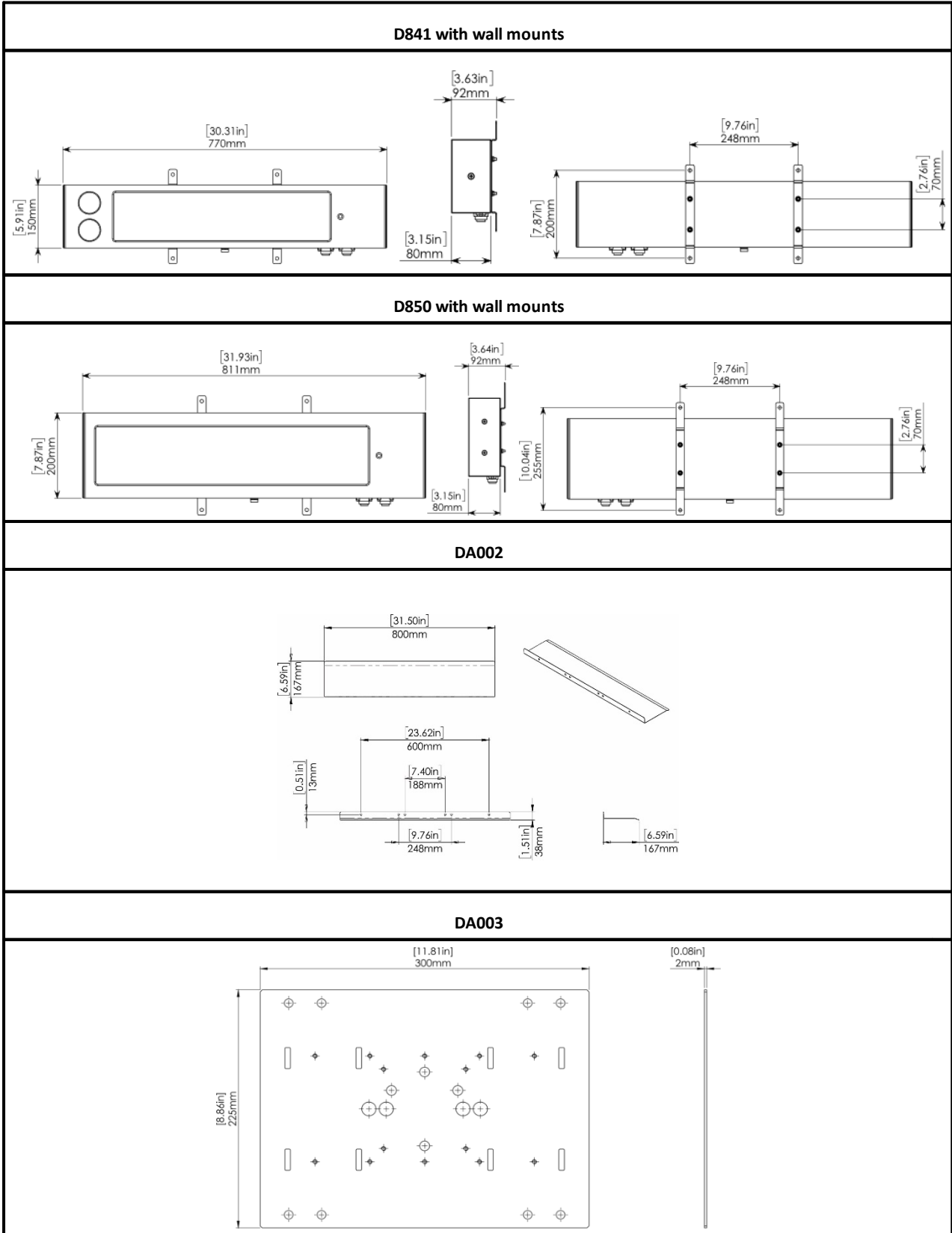

Figure 15: Optional Mounting Plate

8.4 Dimensions



9. ERROR MESSAGES

Error	Description
↓ ↓	Underweight - the weight is below the minimum allowable weight reading as per status. Check source device.
↑ ↑	Overweight - The weight is above the maximum allowable weight reading as per status. Check source device
ERROR	Error - The source device is reporting an error in its status as detected in the protocol. Check source device
--/--	No valid data from indicator and unit has timed out. Check serial /Ethernet input, check cables and connections, confirm protocol/ baud/data-bits are supported then power cycle remote to reset.
PR. 00	If this is being intermittently displayed after the start up sequence, then the received protocol does not match a supported type.

10. APPENDIX A : SUPPORTED PROTOCOLS

The Protocol Table below lists the suggested corresponding manufacturer that each protocol aims to support. Note that compatibility is not guaranteed, and manufacturers may change their protocol at any time without notice.

Protocol	Name	Serial Traffic light support	Unit display support	NTEP multi zero support	Protocol commonly used by indicators from:
1	Ranger A	Yes	No	Yes	Rinstrum, GSE, HBM & PT
2	Ranger B	Yes	Yes	Yes	Rinstrum
3	Ranger C	Yes	Yes	Yes	Rinstrum GSE, HBM & PT
4	Ranger D	Yes	No	Yes	Rinstrum
5	PCMODE	Yes	No	No	Custom software
6	RINCMD	No	No	No	Rinstrum & GSE
7	Avery string #7	No	No	Yes	Avery L105
8	Gedge C2	No	No	No	Gedge
9	Gedge C3	No	No	No	Gedge
10	A&D standard string	No	Yes	No	A & D
11	AD4531	No	No	No	A & D
12	Toledo continuous	No	Yes	Yes	Toledo
13	GSE without COZ	No	Yes	Yes	GSE
14	GSE with COZ	No	Yes	Yes	GSE
15	Schenck without DP	No	Yes	No	Schenck
16	Schenck with DP	No	Yes	No	Schenck
17	Auto control string 1	No	No	No	Auto control PC Software
18	Auto control string 2	No	No	No	Auto control PC software
19	Sartorius	No	No	No	Sartorius
20	Soehnle without DP	No	No	No	Soehnle
21	Soehnle with DP	No	No	No	Soehnle
22	Flintab	No	No	No	Flintab
23	Philips	No	No	No	Philips
24	Condec	No	Yes	Yes	UMC, GSE, Rice Lake, Cardinal, Fairbanks, Eaton, Transcell
25	Bilanciai DS410	No	No	No	Bilanciai

26	Systec	No	Yes	No	Systec
28	Fairbank	Yes	Yes	No	Fairbank
29	Digistar	No	No	No	Digistar
40	Configuration	N/A	N/A	N/A	Changing settings
41	Scrolling	Yes	No	No	K802 firmware only

Refer Remote Display Protocol Manual for detailed protocol descriptions.