

displays



highly visible indoors or out tough, versatile & reliable



(industrial displays)

Rinstrum's large remotes are highly visible displays that are built for industrial applications for both indoors and out. The range of large remote displays includes the **D640**, **D740** and **6500**, they feature:

- RS232, RS485 and 20mA loop serial input
- 3 annunciators (Net, Motion, Centre-of-Zero)
- Shatterproof laminated glass window
- Compatibility with a wide range of indicators

The meaningful display, with annunciators and numeric and alpha characters, and the highly visible digits allow for precise reading across long distances.

Tough Housings

The housing are designed and built for industrial environments with accessories for versatile mounting.

- Shatterproof laminated glass
- Powder coated aluminum extrusion
- Weatherhood
- Swivel arm for directional wall or pole mounting

This combination of features ensures the displays will reliably work in rugged environments with reduced safety concerns and reduced risk of damage from weather or knocks.



Wide Range of Compatible Indicators

Auto-detecting setup with a wide range of indicators combined with the ability to programme from a PC simplifies the display set-up and maintenance.

Rinstrum Indicators: R Series - R320 & R420 and Ranger Series – 2100 & 5000

Selected indicators from: Mettler Toledo, Avery, GSE Scale Systems, HBM, Systec, Gedge, A & D and custom configurations



D640 and D740

- The **D740** range use a double row of highly reliable super bright LED's to create a display that is visible in all lighting conditions, even in direct sunlight
- The **D640** range uses a 7x5 electromechanical dot matrix for each digit (35 dots per digit), allowing full alpha numeric characters to be displayed for even greater clarity
- Available in a variety of configurations from 5 to 7 digits
 - Easy PC setup or firmware upgrades using the magnetically coupled infra-red communications on the front pane
 - DC versions (**D641** and **D741**) make these displays suitable for installation into DC environments directly



6500

- The 6500 uses a 5x3 electromechanical dot matrix for each digit (15 dots per digit), making a highly visible display in a compact housing
- In Summing Mode the 6500 acts as the master controller for a number of slave 5000 units connected together on a multi-drop serial RS485 bus. The 6500 displays the total weight
- Easy PC setup or firmware upgrades using the RS232 connection on the front pane

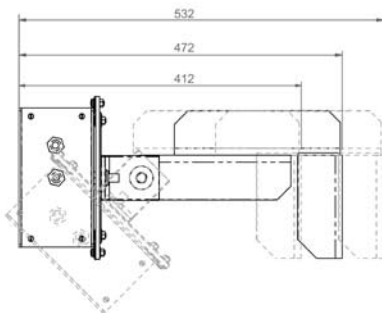
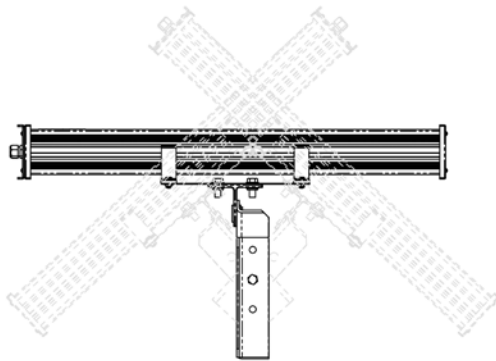

Versatile mounting options

(summing master controller)

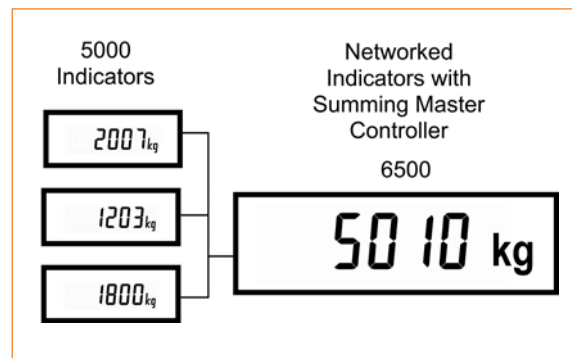

remote displays
THAT'S WEIGHING SMART

Performance (Large remotes)	D640	D740	6500
Display	Up to seven (7) digits 35 segments per digit Full alpha numeric characters	Up to seven (7) digits 68 LED's per digit Numeric and semi-alpha characters	Six (6) digits 15 segments per digit Numeric and semi-alpha characters
Display Type	Electromechanical	Super Bright LED's	Electromechanical
Digit Height	125mm	120mm	75mm
Status Annunciators	Motion, Centre of Zero and Net		
Visibility	Up to 100m		Up to 40m
Operating Environment	Temperature: -10 to +50°C case temperature Humidity: <90%rh non-condensing Storage: -20 to +50°C ambient		
Setup	Auto detecting to compatible indicators		Built-in menus
Memory	Full non-volatile operation		
External Dimensions	850 (L) x 202 (H) x 109 (D) mm		600 (L) x 148 (H) x 78 (D)
Display Window	671 (L) x 141 (H) mm		430 (L) x 100 (H) mm
Weight	10kg		5kg
Serial Communications	RS232 – receive only RS485 – receive only 20mA Current Loop - receive only		RS232 RS485 20mA Current Loop - receive only
AC Power	110/240VAC 50/60Hz 25W		110/240VAC 50/60Hz 15W
DC Power (D641/D741)	12-24VDC		-
Optical Data Communications	Magnetically coupled infra-red communications Conversion cables available for RS-232 or USB		
Approvals	FCC, CE, C-tick Complies with S1/0 for auxiliary devices, suitable for trade applications		
Unit Addressing	Up to 7		Up to 99
Features	Display timeout available Font selectable for curved or blocked	Display timeout available Selectable brightness	Display timeout available Summing up to 10 units
PC Programming	PC programmable using Viewer software		
Options	Weather Hood, Pole Mount, Swivel Mount		

Large Remote Displays Dimensions in mm (1 inch = 25.4 mm)

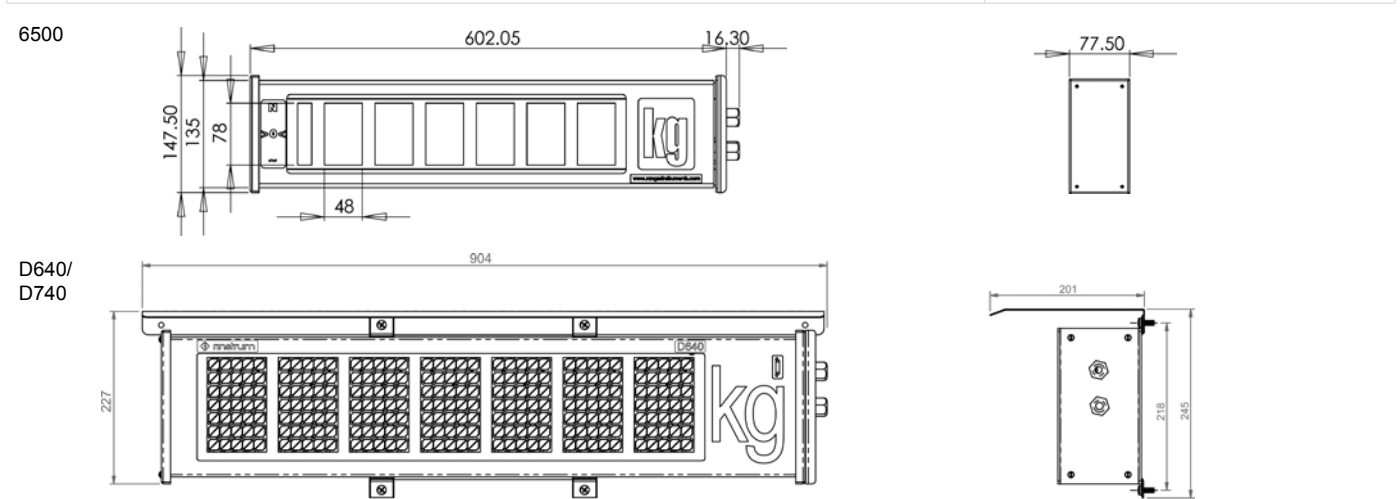

Australian Sales Office
41 Success Street
Acacia Ridge
Queensland 4110 Australia

European Sales Office
Rinstrum Europe GmbH
Donnersberggring 14 – 18
64295 Darmstadt

Phone +61 7 3216 7166
Fax +61 7 3216 6211
Email: sales@rinstrum.com

Phone: +49(0)6151-13617-0
Fax: +49(0)6151-13617-29
Email: info@rinstrum.de

www.rinstrum.com